

► **Store Fixturing: Counters "Radiused"**

Radiused Sales Counter

Handsome, durable and functional are a few words to describe our "Three Sectional Service" counters. These commercial grade counters are manufactured to address the need for customer interaction, product display and sales transaction all within a limited space. The 45° or 90° middle section along with the 48" or 72" wide POS stations are designed to create a spacious area whereby one or more sales persons can handle a variety of transactions simultaneously. The angle or curved middle counter creates a continuous counter surface between the POS counters and gently angles them to decrease the "footprint" area. Each center section is constructed with the finest commercial grade materials, including heavy duty drawer glides, printer shelf guides and monitor cradles. All our features are designed to provide years of use, even in the "busiest retail environment". Each counter ensemble consists of three sections; two point of sale counters and one product display counter. POS counters are available in 48" and 72" wide formats that seamlessly integrate with the middle counter. The middle counter is constructed in full 42" height and is available in a solid top or showcase top. All counter sections are compatible with wire access "doors" located in each base and wire" openings in divider panels.

Installation is simple, all sections have been previously setup and rigorously inspected for a quality fit.

To install, simply place the middle section in the area of use and then position each POS, level and screw together. All installation material is provided to insure a quick and easy installation.



CN-0167 90° Radius Sales Counter with Showcase Center Section ▲

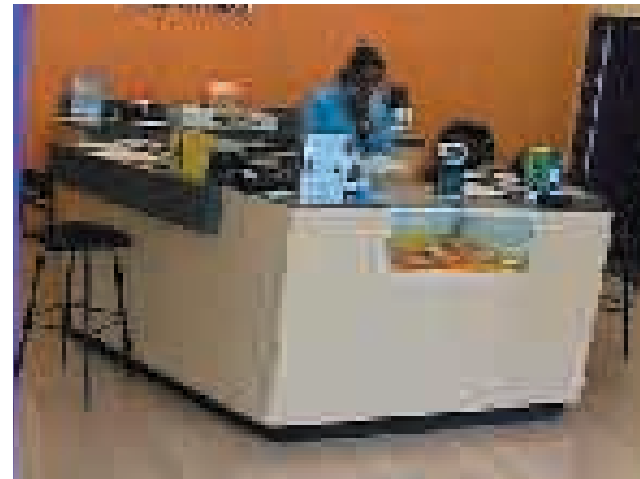

CN-0145 45° Sales Counter with Showcase Center Section ▲



"Built to Last"

- Accessories
- Printer Shelves
- File Drawers
- Monitor Cradles
- Cash Drawer
- Storage Compartment and more . . .



Order by phone or fax today!

972.980.7320 ph.

972.980.8424 fx.

▼ **CN-0124 90° Sales Counter with Showcase Center Section**

▼ **CN-0108 90° Sales Counter with Solid Center Section**

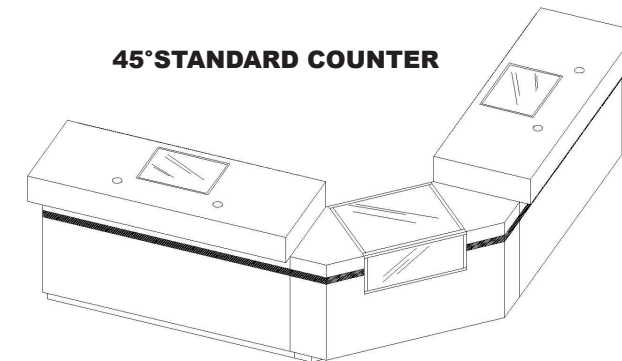

45° STANDARD COUNTER

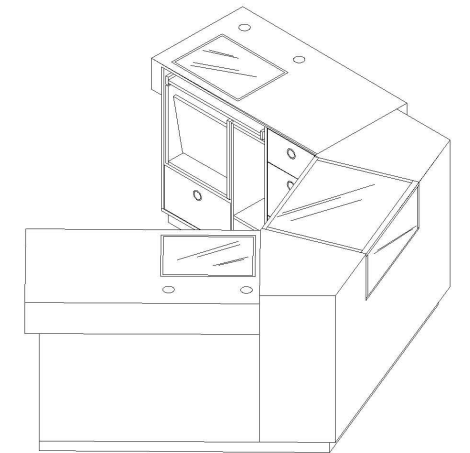

Modular Sales/Showcase/Counter Ensemble

Counter Sizes:

POS - Straight Design: 48" or 72" (w) x 42"(h) x 27" (d)
Center - 45° or 90°: 72" (w) x 42" (h) x 24" (d)

Counter Top Features:

- POS top solid or contains glass covered opening for monitor viewing. Middle section contains glass showcase. All glass is 1/4" tempered commercial grade.

Color Descriptions:

Exterior surfaces to be domestic commercial grade High Pressure Plastic Laminate. Interior surfaces are covered with White, Grey or Almond thermofused melamine. Exterior colors may be custom colors of domestic High Pressure Plastic Laminate brands.

General Features:

- All counters have heavy-duty cash and file drawers with heavy-duty sliding track for frequent use.
- Adjustable shelves have an easy mechanism to move up or down.
- Showcases have sliding doors with keyed locks.
- Counter top has wire access openings for electrical and telephone cables.
- POS counters have a monitor cradle designed for sizes up to 17". The heavy-duty slides allow the cradle to move in and out for monitor installation and operation.
- Sliding keyboard and printer shelf on each POS counter.
- All toe kicks are prefinished in black.
- Showcases have a brushed aluminum casing finish on the customer side and counter's top surface.

CN-0145 45° Sales Counter with Showcase Center Section ▲

CN-0145M 90° Sales Counter with Showcase Center Section ►

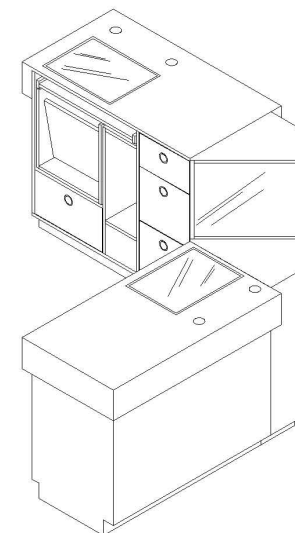

CN-0167M 45° Radius Sales Counter with Showcase Center Section ►

CN-0167 90° Radius Sales Counter with Showcase Center Section

